

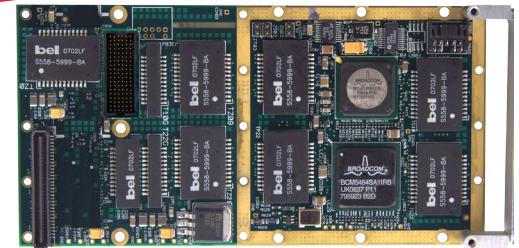

# XMC-651 PMC-651

## 5/8/12-Port Gigabit Ethernet Switch

- ◆ 12-port Gigabit Ethernet switch
  - Supports 8-port 10/100/1000Base-T plus 4 ports SerDes (1000Base-BX)
- ◆ Non-blocking line-speed Ethernet switching
- ◆ Supports jumbo packets up to 16K bytes
- ◆ IEEE 802.3 compliant
- ◆ Managed Layer-2 features include VLAN, L2 multicast, QoS services
- ◆ Support for port mirroring and link aggregation
- ◆ Flexible I/O on Pn4 and Pn6
  - XMC or PMC with Pn4 IO supports 8 ports Base-T
  - XMC with Pn6 IO supports 5 ports Base-T
  - XMC with Pn4/Pn6 IO supports 8 ports Base-T on Pn4 plus 4 ports SerDes on Pn6
- ◆ No software required, only power and I/O from basecard
- ◆ Range of air and conduction-cooled ruggedization levels available



### Overview

The XMC-651 and PMC-651 are Gigabit Ethernet switches packaged in the industry-standard XMC and PMC form factors. They are designed to support “in-chassis” networks with managed Layer-2 switching capabilities. Part of a family of Gigabit Ethernet switching/routing products from Curtiss-Wright Controls Embedded Computing, the '651 is a zero-slot Ethernet switching solution that can be added to any basecard with an XMC or PMC mezzanine slot. These switches are designed for rugged applications with backplane I/O and is offered in a full range of ruggedized air- and conduction-cooled versions.

### Ethernet Switching

The '651 implements Ethernet switching functions via Broadcom® 10<sup>th</sup> generation switching technology. Eight ports support 10/100/1000Base-T with auto-negotiation. An additional 4 ports support SerDes (1000Base-BX) GbE, offering flexibility in connecting in-chassis devices. The '651 implements Layer-2 Ethernet switching with full wire-speed performance on all ports and features an 8K entry MAC address table, with automatic learning, advanced flow-control and head of line blocking prevention.

### Connectivity

The '651 routes eight Base-T ports through the Pn4 connector. For XMC modules without Pn4, five Base-T ports are routed through the Pn6 connector. For configurations using both Pn4 and Pn6, the eight Base-T ports are routed to Pn4, and four additional SerDes ports are routed to Pn6 for a total of 12 GbE ports. This configuration is very useful when building systems populated with a mix of Base-T and SerDes payload modules.

Learn More

Sales Info: [sales.cwembedded.com](mailto:sales.cwembedded.com)

Sales Email: [sales@cwembedded.com](mailto:sales@cwembedded.com)

**ABOVE & BEYOND**



# XMC-651 PMC-651

All models provide a serial RS232 port for configuration. Air-cooled variants support a front-panel RJ45 serial connection. Conduction-cooled variants provide serial port access using an innovative back-of-the-board access header and cable.

The '651 only connects to the XMC and PMC connectors to obtain power and for Ethernet I/O connections. No software driver is needed.

**Table 1: Recommended Variants**

Part Number	Ruggedization	Description
XMC-651-A03808	AC L0	XMC Managed L2 GbE switch, Pn4/Pn5, 8 ports 1000Base-T on Pn4
XMC-651-A13808	AC L100	
XMC-651-C23808	CC L200	
XMC-651-A04812	AC L0	XMC Managed L2 GbE switch, Pn4/Pn5/Pn6, 8 ports 1000Base-T on Pn4, 4 ports SerDes on Pn6
XMC-651-A14812	AC L100	
XMC-651-C24812	CC L200	
XMC-651-A02505	AC L0	XMC Managed L2 GbE switch, Pn5/Pn6, 5 ports 1000Base-T on Pn6
XMC-651-A12505	AC L100	
XMC-651-C22505	CC L200	
SPMC-651-A01808	AC L0	PMC Managed L2 GbE switch, Pn1/Pn4, 8 ports 1000Base-T on Pn4
SPMC-651-A11808	AC L100	
DPMC-651-C21808	CC L200	

Note: Refer to the Curtiss-Wright Controls Embedded Computing website for ruggedization details

**Table 2: Dimension and Weight**

Option	Dimensions	Weight (grams)
Air-cooled	per IEEE 1386.1	< 101
Conduction-cooled	per IEEE 1386.1 (VITA 20-199x)	< 70

## Part Number

Ordering information for the XMC-651 and PMC-651 is provided below.

XMC-651- UVWXY  
SPMC-651- UVWXY  
DPMC-651-UVWXY

- YY = Total number of Ethernet ports  
05: 5 ports Base-T  
08: 8 ports Base-T  
12: 8 ports Base-T + 4 ports SerDes
- X = Number of Base-T ports
- W = Connector option  
1: PMC connectors Pn1/4  
2: XMC connectors Pn5/6  
3: XMC connectors Pn4/5  
4: XMC connectors Pn4/5/6
- V = Ruggedization Level  
0: Level 0, 0 to +50°C  
1: Level 100, -40 to +71°C  
2: Level 200, -40 to +85°C
- U = Cooling method  
A: Air-cooled  
C: Conduction-cooled

**Figure 1: XMC-651 Block Diagram**

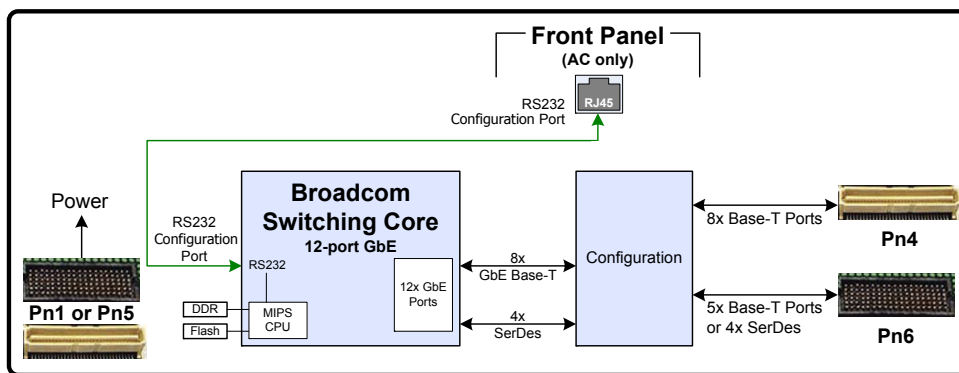

## UNITRONIX Pty Ltd

PO Box 486, Morisset NSW 2264

NSW: Tel: 61 2 4977 3511 Fax: 61 2 4977 3522

WA: Tel: 61 8 9455 2424 Fax: 61 8 9455 2458

unitsyd@unitronix.com.au www.unitronix.com.au